

connection plan RM16

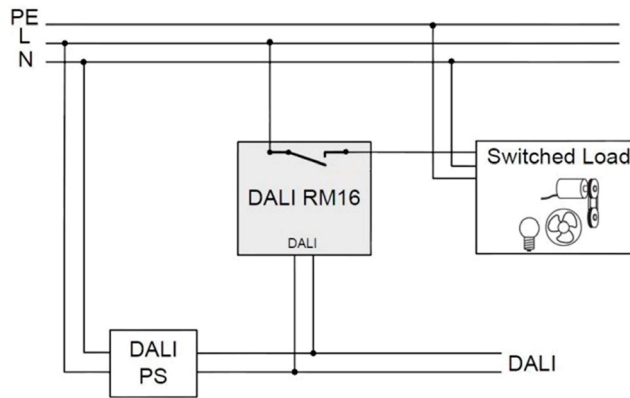

typical application



Hint: In order to ensure that the load current does not exceed the maximum switching current, the installation must be secured with a suitable automatic circuit breaker.

Installation

The relay module is supplied directly by the DALI-line. It must NOT be connected to the mains. A typical value of current consumption is 2.7mA. In order to supply components on a DALI line the installation of a DALI power supply (DALI PS) is necessary. The connection to the DALI line is polarity free. The DALI input is protected against overvoltage up to 250VAC. For RM8/16 and RM16-DE types internally the DALI-terminals are connected through as visualized on the housing (see connection plan).

The relay output of the RM8/16 supports loads up to 2000VA and switching currents up to 16A (type dependent, check specification for details). In order to ensure that the load current does not exceed the maximum switching current of the relay a suitable automatic circuit breaker has to be installed. Switching is done at zero cross of ac voltage, type RM16 DE and RM16 HS are also equipped with integrated current limiter and are therefore dedicated for loads with high inrush current >100A.

DALI Functions and Instruction Set

The DALI RM 8/16 acts as a DALI-controlled relay contact. Hence ballasts can be integrated in a DALI-system and switched on and off by DALI commands.

The DALI RM8/16 acts like a standard DALI ballast for non-dimmable loads. It is based on the DALI specification for control gear (IEC 62386-102) and the device type 7 extension (IEC 62386-208). Therefore the switching characteristic is determined by the comparison of the virtual direct arc power level (VDAP) with 4 thresholds.

The virtual dim level (VDAP) is like the dim level of DALI-ballasts and is therefore limited by MINLEVEL and MAXLEVEL and influenced by fade-time and fade-rate.

For each dim direction 2 thresholds can be defined. They are compared with the virtual dim level and as a result the output is switched on or off:

virtual dim direction	comparison of virtual dim level and thresholds	output
UP	VDAP >= UP SwitchOn Threshold	ON
UP	VDAP >= UP SwitchOff Threshold	OFF
DOWN	VDAP <= DOWN SwitchOn Threshold	ON
DOWN	VDAP <= DOWN SwitchOff Threshold	OFF

If a threshold value is set to "MASK" the threshold is inactive and does not influence the relay output.

Find some examples of switching characteristics below:

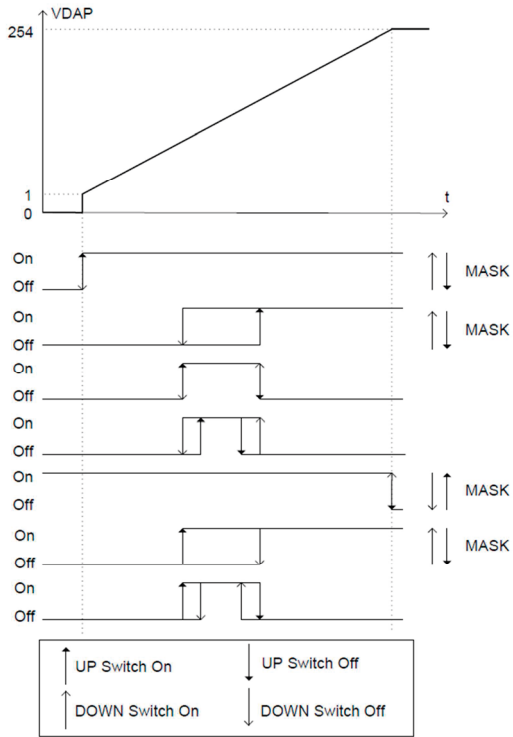

With the help of the fade time switch on and switch off delays can be realized.

The DALI RM8/16 is bus-powered. The reaction on a system failure can be configured (keep relay state, on or off, factory default: on). In case of switching on the DALI-line supply voltage the Power On level is applied.

Addressing and Configuration

The DALI RM 8/16 can be addressed (random addressing) and configured with the help of the DALI-Cockpit, a software tool, that can be downloaded from the Lunatone website.

Purchase Information

Art.Nr. 86458629-HS: DALI RM16, 2000VA/16A, zero cross switching, integrated current limiter, 1 normal open, rail mounting

Art.Nr. 86458629-HS-WE: DALI RM16, 2000VA/16A, zero cross switching, 1 changeover, rail mounting

Art.Nr. 86458675-HS: DALI RM8, 1000VA/8A, zero cross switching, 1 normal open, rail mounting

Art. Nr. 86458629-DE: DALI RM16, 2000VA/16A, zero cross switching, integrated current limiter, 1 normal open, remote ceiling

Art. Nr. 86458629-DE-WE: DALI RM16, 2000VA/16A, zero cross switching, 1 changeover, remote ceiling

Art. Nr. 86458629-CEL: DALI RM16, 2000VA/16A, 1 normal open, fast commissioning (plug)

Art. Nr. 86458629: DALI RM16, 1000VA/8A, zero cross switching, 1 changeover, back box

Art. Nr. 86458675: DALI RM8, 1000VA/8A, zero cross switching, 1 normal open, back box